

Trigonometrical ratios in a right-angled triangle

mc-TY-trigratios-2009-1

Knowledge of the trigonometrical ratios sine, cosine and tangent, is vital in very many fields of engineering, mathematics and physics. This unit introduces them and provides examples of how they can be used in the solution of problems.

In order to master the techniques explained here it is vital that you undertake plenty of practice exercises so that they become second nature.

After reading this text, and/or viewing the video tutorial on this topic, you should be able to:

- define the ratios sine, cosine and tangent with reference to a right-angled triangle.
- use the trig ratios to solve problems involving triangles.
- quote trig ratios for commonly occurring angles.

Contents

1. Introduction	2
2. Introducing the tangent ratio	2
3. Labelling the sides of a right-angled triangle	3
4. The sine, cosine and tangent ratios	3
5. Remembering the definitions	4
6. Examples	5
7. Some common angles and their trig ratios	9

1. Introduction

In this unit we are going to be having a look at trigonometrical ratios in a right-angled triangle. We will usually refer to these as 'trig ratios' for short.

2. Introducing the tangent ratio

Study the diagram in Figure 1. On the horizontal line we have marked the points O , A_1 , A_2 and A_3 , and each of these points is 10 cm apart. We have drawn vertical lines from the points A_1 , A_2 and A_3 to form right-angled triangles.

There is an angle marked at O , and this angle remains the same even though the separation of the lines OA_3 and OB_3 increases as we move away from O .

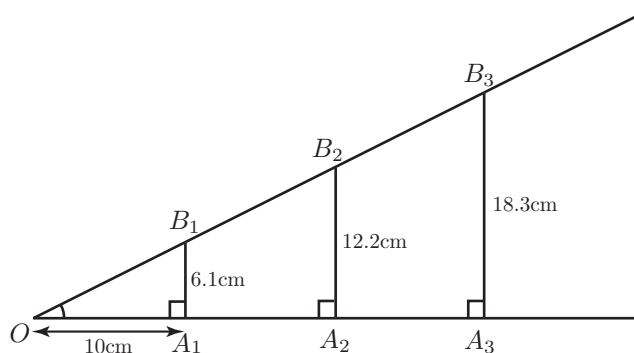

Figure 1. The angle marked at O remains the same as we move further from O .

We want to study the ratio of A_1B_1 to OA_1 , of A_2B_2 to OA_2 and of A_3B_3 to OA_3 . Using a ruler we have measured A_1B_1 and found it to be 6.1 cm.

So

$$\frac{A_1B_1}{OA_1} = \frac{6.1}{10} = 0.61$$

Similarly, we have measured A_2B_2 and found it to be 12.2 cm. So

$$\frac{A_2B_2}{OA_2} = \frac{12.2}{20} = 0.61$$

Finally, we have measured A_3B_3 and found it to be 18.3 cm. So

$$\frac{A_3B_3}{OA_3} = \frac{18.3}{30} = 0.61$$

We see that all of the three ratios are the same. So if we take the length of the side in a right-angled triangle which is *opposite* to an angle and we divide it by the length of the side which is *adjacent* to it, then the ratio

$$\frac{\text{OPPOSITE}}{\text{ADJACENT}} = \text{constant for the given angle}$$

We have a name for this ratio. We call it the **tangent** of the angle.

3. Labelling the sides of a right-angled triangle

Consider Figure 2.

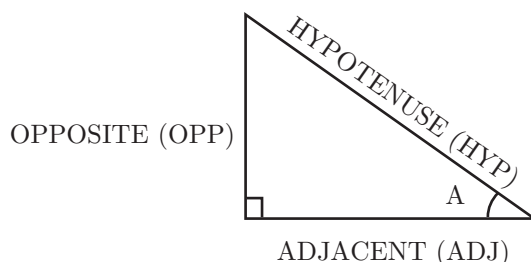

Figure 2. A right-angled triangle with angle A marked.

The longest side of a right-angled triangle is always called the **hypotenuse**, usually shortened to HYP. This side is always opposite the right-angle. The side opposite angle A has been labelled OPP, and the remaining side, which is adjacent to A has been labelled ADJ.

Notice that if we look at a different angle, some of these quantities change. Consider Figure 3.

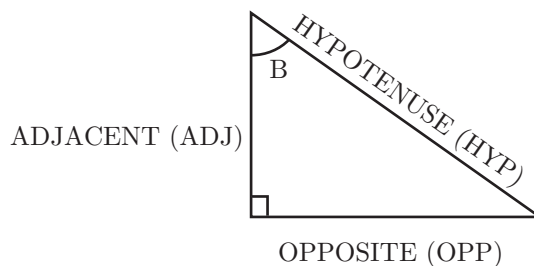

Figure 2. A right-angled triangle with angle B marked.

The hypotenuse is as it was in Figure 2, but the other two labels have changed.

4. The sine, cosine and tangent ratios

Referring to Figure 4, recall that we have already named the ratio $\frac{\text{OPPOSITE}}{\text{ADJACENT}}$ as the tangent of the given angle. We usually shorten this to simply tan. So

$$\text{tangent } A = \tan A = \frac{\text{OPP}}{\text{ADJ}}$$

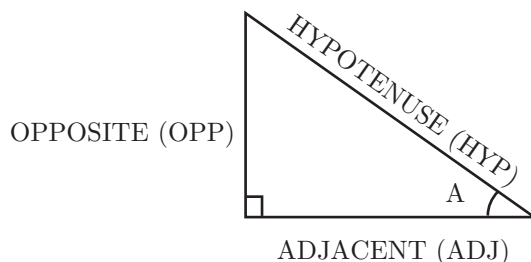

Figure 4. A right-angled triangle with angle A marked.

We can also calculate some other ratios from this triangle.

The ratio $\frac{\text{OPP}}{\text{HYP}}$ is called the sine of A which we abbreviate to $\sin A$.

The ratio $\frac{\text{ADJ}}{\text{HYP}}$ is called the cosine of A which we abbreviate to $\cos A$.

All of these ratios have already been worked out and are available in published tables. Before the days of calculators mathematicians used to work these out quite regularly and publish books of tables of the sines, cosines and tangents of all the angles through from 0 to 90° . Nowadays a calculator is invaluable and you really do need one for this sort of work.

5. Remembering the definitions

It will help if you have a way of recalling these definitions. One of these ways is by remembering a nonsense word:

SOH TOA CAH

sine is opposite over hypotenuse,
tangent is opposite over adjacent
and cosine is adjacent over hypotenuse.

Some people remember it as

SOH CAH TOA

simply changing the syllables around.

Others remember it by a little verse:

Tom's Old Aunt (TOA)
Sat On Him (SOH)
Cursing At Him. (CAH)

Whichever you learn, it will be helpful in order to remember these ratios.



Key Point

$$\sin A = \frac{\text{OPPOSITE}}{\text{HYPOTENUSE}}, \quad \cos A = \frac{\text{ADJACENT}}{\text{HYPOTENUSE}}, \quad \tan A = \frac{\text{OPPOSITE}}{\text{ADJACENT}}$$

6. Examples

Example

Many of the examples that we want to look at actually come from the very practical area of surveying - the problem of finding out the size of something, or the length of something, when you cannot actually measure it, perhaps the height of a tower. So suppose we want to know the height of the tower in Figure 5.

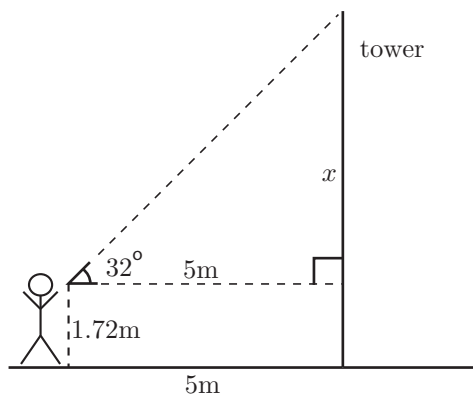

Figure 5.

It is possible to measure the angle between the horizontal and a line from a surveying instrument to the top of the tower. Suppose this angle has been found to be 32° as shown. It is also straightforward to measure how far away we are standing from the base of the tower. Suppose this is 5m. Suppose the height of the person doing the surveying is 1.72m. So how high is the tower ?

Observe the right-angled triangle in Figure 6. The side we wish to find is **opposite** the angle of 32° as shown in Figure 6. We know the **adjacent** side is 5m. So we ask 'what trig ratio links opposite and adjacent ?' The answer is the tangent ratio.

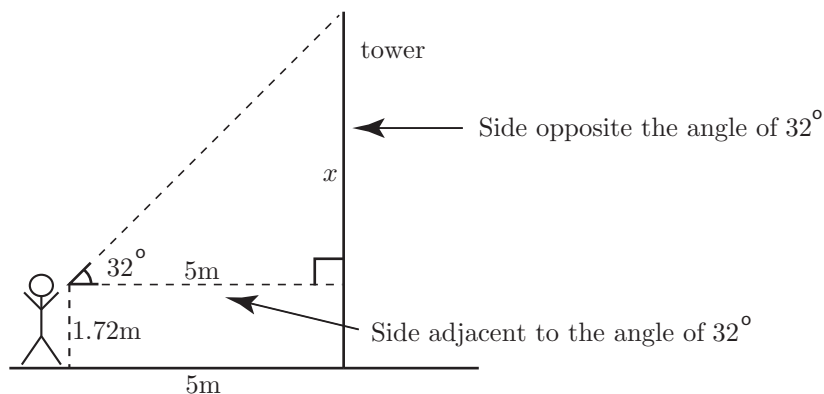

Figure 6.

Let the length of the opposite side be x . Then

$$\begin{aligned}\frac{\text{OPP}}{\text{ADJ}} &= \tan 32^\circ \\ \frac{x}{5} &= \tan 32^\circ \\ x &= 5 \times \tan 32^\circ\end{aligned}$$

We now need a calculator to evaluate $\tan 32^\circ$. You should check for yourself that $5 \times \tan 32^\circ = 3.124$. One word of warning: most calculators operate with angles measured in one of two ways, degrees or radians. You need to make sure the calculator is operating with the correct measurement of the angle, in this case, degrees. So, continuing,

$$\begin{aligned}x &= 5 \times \tan 32^\circ \\ &= 3.124\end{aligned}$$

Finally the height of the tower can be found by adding on the height of the surveyor:

$$\begin{aligned}\text{height} &= 3.124 + 1.72 \\ &= 4.844 \text{ m} \\ &= 4.8 \text{ m} \quad (2 \text{ s.f.})\end{aligned}$$

So, the height of the tower is 4.8m.

Exercise 1

1. The angle of elevation of the top of a tree from a point on the ground 10 m from the base of the tree is 28° . What is the height of the tree (to 1 decimal place)?
2. Using a surveying instrument 1.6 m high, the angle of elevation of the top of a tower is measured to be 55° from a point 6 m from the base of the tower. How high is the tower (to 1 decimal place)?
3. The angle of elevation of the top of a 20 m high mast from a point at ground level is 34° . How far is the point from the foot of the mast (to 1 decimal place)?

Example

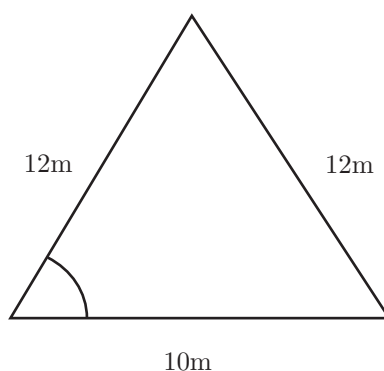

Figure 7.

In this Example consider the isosceles triangle shown in Figure 7. Suppose we wish to find the marked angle. In this Example there does not appear to be a right-angle. In questions like this you must look to introduce a right-angle for yourself. If we divide the isosceles triangle in half we can form a right-angle as shown in Figure 8. We have labelled the required angle A . From studying Figure 8 you will see that we know the hypotenuse and the adjacent side of the

right-angled triangle and so we use the cosine ratio.

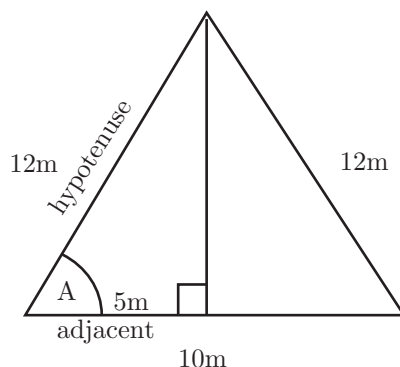

Figure 8.

$$\begin{aligned}\cos A &= \frac{\text{ADJ}}{\text{HYP}} \\ &= \frac{5}{12}\end{aligned}$$

So the angle we want, A , is an angle which has a cosine equal to $\frac{5}{12}$. We have a way of writing this:

$$A = \cos^{-1} \frac{5}{12}$$

This is read as ' A is the angle whose cosine is $\frac{5}{12}$ '. Note that the -1 does not denote a power. Your calculator will have a button marked \cos^{-1} in order to do this calculation. Check that you can use it correctly to find

$$\begin{aligned}A &= \cos^{-1} \left(\frac{5}{12} \right) \\ &= 65.3757^\circ \\ &= 65.4^\circ \text{ (1 d.p.)}\end{aligned}$$

So, the required angle has been shown to be 65.4° .

Example

Suppose we wish to find the height of the isosceles triangle in Figure 9. In this example we want to know the length, h say, of the side opposite the angle of 72° , and we know the length of the hypotenuse. The ratio which links the opposite and the hypotenuse is the sine.

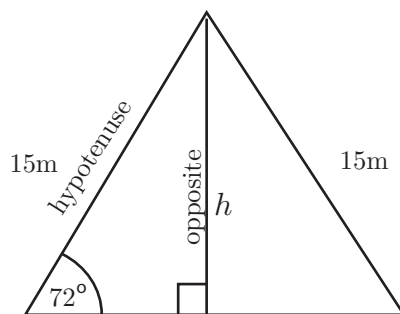

Figure 9.

$$\begin{aligned}\frac{\text{OPP}}{\text{HYP}} &= \sin 72^\circ \\ \frac{h}{15} &= \sin 72^\circ \\ h &= 15 \times \sin 72^\circ \\ &= 14.3 \text{ m (3 s.f.)}\end{aligned}$$

So we have shown that the height of the triangle is 14.3m.

Exercise 2

1. An isosceles triangle has base 8 cm and sloping sides both with length 10 cm. What is the base angle of this triangle (to the nearest degree)?
2. A supporting cable of length 30 m is fastened to the top of a 20 m high mast. What angle does the cable make with the ground? How far away from the foot of the mast is it anchored to the ground (to 1 decimal place)?
3. A right-angled triangle has sides 5, 12, 13. What is the size of the smallest angle in this triangle (to the nearest degree)?

Example

Consider the right-angled triangle shown in Figure 10. Suppose we wish to find the length of the hypotenuse.

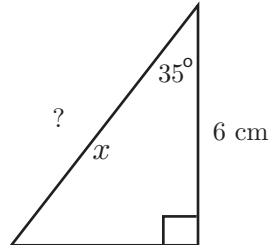

Figure 10.

We know the adjacent side is 6 cm. We want to know the hypotenuse, x , say. The ratio which links these is the cosine.

$$\begin{aligned}\frac{\text{ADJ}}{\text{HYP}} &= \cos 35^\circ \\ \frac{6}{x} &= \cos 35^\circ \\ 6 &= x \cos 35^\circ \\ \frac{6}{\cos 35^\circ} &= x \\ x &= 7.3246 \\ &= 7.32 \text{ m (3 s.f.)}\end{aligned}$$

Exercise 3

1. What is the height (to 1 decimal place) of an isosceles triangle with base angle 65° and sloping sides with length 10 cm? What is the length of the base of this triangle (to 1 decimal place)?
2. One angle in a right angled triangle is 50° and the side opposite this angle has length 5 cm. What is the length of the hypotenuse (to 1 decimal place)?
3. In a right angled triangle, the hypotenuse has length 8 m and one angle is 55° . What is the length of the shortest side (to 1 decimal place)?

7. Some common angles and their trig ratios

One of the things that we need to have a look at are some quite specific angles and their sines, cosines and tangents. It is important that these are learnt - this is because they are exact and because mathematicians, scientists and engineers use these a great deal in their work.

The angles that we are talking about are 0° , 30° , 45° , 60° and 90° .

Consider Figure 11 which shows a right-angled isosceles triangle with angles of 45° , 45° , and 90° .

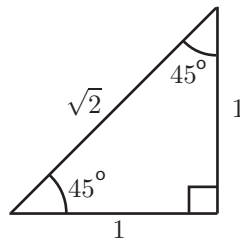

Figure 11.

From this triangle we can deduce

$$\sin 45^\circ = \frac{1}{\sqrt{2}}, \quad \cos 45^\circ = \frac{1}{\sqrt{2}}, \quad \tan 45^\circ = \frac{1}{1} = 1$$

Now consider the equilateral triangle shown in Figure 12. All sides have length 2. All angles will be 60° .

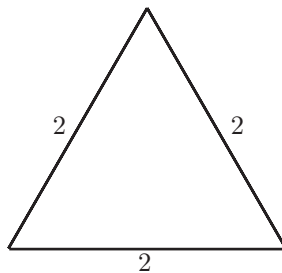

Figure 12.

If we split the triangle in half we can introduce angles of 30° as shown in Figure 13. The height of the triangle can be obtained using Pythagoras' theorem. It is $\sqrt{3}$.

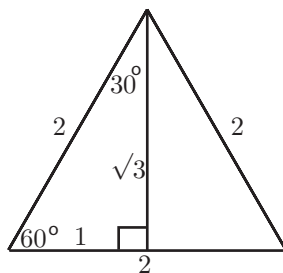

Figure 13.

From Figure 13 we can deduce

$$\sin 30^\circ = \frac{1}{2}, \quad \cos 30^\circ = \frac{\sqrt{3}}{2}, \quad \tan 30^\circ = \frac{1}{\sqrt{3}}$$

$$\sin 60^\circ = \frac{\sqrt{3}}{2}, \quad \cos 60^\circ = \frac{1}{2}, \quad \tan 60^\circ = \sqrt{3}$$

All of the above results, and results for angles of 0° and 90° are summarised in the table below.

	0°	30°	45°	60°	90°
sin	0	$\frac{1}{2}$	$\frac{1}{\sqrt{2}}$	$\frac{\sqrt{3}}{2}$	1
cos	1	$\frac{\sqrt{3}}{2}$	$\frac{1}{\sqrt{2}}$	$\frac{1}{2}$	0
tan	0	$\frac{1}{\sqrt{3}}$	1	$\sqrt{3}$	∞

This is a table of sines, cosines and tangents that are all **EXACT** and for very specific angles: 0° , 30° , 45° , 60° and 90° . Textbooks, scientists and engineers in their everyday working and in their everyday calculations take these as being read. They assume that they are known, so you must learn them too!

Exercise 4

In these questions you should give your answer exactly by using square roots where appropriate.

1. What is the height of an equilateral triangle with side 12 cm?
2. An isosceles triangle has base angle of 30° and base $10\sqrt{3}$ cm long. What is the height of this triangle? What is the length of the two equal sides?
3. In a right angled triangle, one angle is 45° and the side next to this angle (not the hypotenuse) has length 5 cm. What is the length of the hypotenuse?

Answers

Exercise 1

1. 5.3 m
2. 10.2 m
3. 29.7 m

Exercise 2

1. 66°
2. 42° , 22.4 m
3. 23°

Exercise 3

1. 9.1 cm, 8.5 cm
2. 6.5 cm
3. 4.6 m

Exercise 4

1. $6\sqrt{3}$ cm
2. 5 cm, 10 cm
3. $5\sqrt{2}$ cm